

TB 9-6625-2308-35

CHANGE 1

DEPARTMENT OF THE ARMY TECHNICAL BULLETIN

CALIBRATION PROCEDURE FOR POWER METER, GIGA-TRONICS, INC. MODEL 8542 AND POWER SENSOR, GIGA- TRONICS, INC. MODEL 80301A

Headquarters, Department of the Army, Washington, DC
7 September 2005

Distribution Statement A: Approved for public release; distribution is unlimited.

TB 9-6625-2308-35, 2 November 2004, is changed as follows:

1. Remove old pages and insert new pages as indicated below. New or changed material is indicated by a vertical bar in the margin of the page.

Remove Pages

11 and 12

Insert Pages

11 and 12

2. File this change sheet in front of the publication for reference purposes.

By Order of the Secretary of the Army:

Official:



SANDRA R. RILEY

*Administrative Assistant to the
Secretary of the Army*

0518803

PETER J. SCHOOMAKER
*General, United States Army
Chief of Staff*

Distribution:

To be distributed in accordance with IDN 344603, requirements for calibration procedure
TB 9-6625-2308-35.

*TB 9-6625-2308-35

DEPARTMENT OF THE ARMY TECHNICAL BULLETIN

CALIBRATION PROCEDURE FOR POWER METER, GIGA-TRONICS, INC. MODEL 8542 AND POWER SENSOR , GIGA-TRONICS, INC. MODEL 80301A

Headquarters, Department of the Army, Washington, DC
2 November 2004

Distribution Statement A: Approved for public release, distribution is unlimited.

REPORTING OF ERRORS AND RECOMMENDING IMPROVEMENTS

You can improve this manual. If you find any mistakes or if you know of a way to improve these procedures, please let us know. Mail your letter or DA Form 2028 (Recommended Changes to Publications and Blank Forms) directly to: Commander, US Army Aviation and Missile Command, AMSAM-MMC-MA-NP, Redstone Arsenal, AL 35898-5000. A reply will be furnished to you. You may also provide DA Form 2028 information to AMCOM via e-mail, fax, or the World Wide Web. Our fax number is DSN 788-6546 or Commercial 256-842-6546. Our e-mail address is 2028@redstone.army.mil. Instructions for sending an electronic 2028 may be found at the back of this manual. For the World Wide Web, use <https://amcom2028.redstone.army.mil>.

SECTION		Paragraph	Page
I.	IDENTIFICATION AND DESCRIPTION		
	Test instrument identification	1	2
	Forms, records, and reports	2	2
	Calibration description	3	2
II.	EQUIPMENT REQUIREMENTS		
	Equipment required.....	4	3
	Accessories required	5	3
III.	CALIBRATION PROCESS FOR POWER METER, GIGA-TRONICS MODEL 8542		
	Preliminary instructions	6	4
	Equipment setup.....	7	4
	Calibrator output	8	5
	Final procedure	9	7
IV.	CALIBRATION PROCESS FOR POWER SENSOR, GIGA-TRONICS MODEL 80301A		
	Preliminary instructions	10	7

*This bulletin supersedes TB 11-6625-2308-35, dated 10 March 2004.

Table 1. Calibration Description - Continued

Cal factor uncertainties (KB)	Frequency	Uncertainty
Cal factor uncertainties (KB)	.1 to 1 GHz	±1.61%
	1.0 to 2.0 GHz	±1.95%
	2.0 to 4.0 GHz	±2.44%
	4.0 to 6.0 GHz	±2.67%
	6.0 to 8.0 GHz	±2.86%
	8.0 to 12.4 GHz	±3.59%
	12.4 to 18.0 GHz	±4.09%

**SECTION II
EQUIPMENT REQUIREMENTS**

4. Equipment Required. Table 2 identifies the specific equipment to be used in this calibration procedure. This equipment is issued with Secondary Transfer Calibration Standards Set AN/GSM-287 or AN/GSM-705, and Secondary Reference Calibration Standards Set NSN 4931-00-621-7878. Alternate items may be used by the calibrating activity. The items selected must be verified to perform satisfactorily prior to use and must bear evidence of current calibration. The equipment must meet or exceed the minimum use specifications listed in table 2. The accuracies listed in table 2 provide a four-to-one ratio between the standard and TI. Where the four-to-one ratio cannot be met, the actual accuracy of the equipment selected is shown in parenthesis.

5. Accessories Required. The accessories required for this calibration are common usage accessories, issued as indicated in paragraph 4 above, and are not listed in this calibration procedure.

Table 2. Minimum Specifications of Equipment Required

Common name	Minimum use specifications	Manufacturer and model (part number)
ATTENUATOR	Range: 0 to 90 dB in 10 dB increments Accuracy: ±0.1 dB	Hewlett-Packard, Model 355D (7910807)
FREQUENCY COUNTER	Range: 50 MHz Accuracy: ±0.5%	Fluke, Model PM6681/656 (PM6681/656)
LOW PASS FILTER	Attenuation: 90 to 95 MHz >32 dB	Telonic, Model TLC-75-6EF1 (TLC-75-6EF1)
MULTIMETER	Range: 0 to 10 V dc Accuracy: ±0.05% Resolution: 1 mV Ohmmeter range: 200 Ω Accuracy: ±1%	Hewlett-Packard Model 3458A (3458A)
POWER METER	Equipped with V _{COMP} and V _{RF} terminals	Hewlett-Packard, Model E12-432A (MIS-30525) w/thermistor mount Hewlett-Packard, Model H75-478A (7915907) or 8478B (8478B)
POWER SPLITTER	Frequency range: 18 GHz Accuracy: ±0.25%	Weinschel, Model 1870A (7916839)
RF AMPLIFIER	Frequency Range: 50 MHz Power range: 0 to +20 dBm	Antenna Research, Model 757LC (MIS45845)
SIGNAL GENERATOR	Range: 50 MHz Accuracy: NA (Input source for RF Amp)	SG-1207/U

**SECTION III
CALIBRATION PROCESS FOR
POWER METER, GIGA-TRONICS MODEL 8542**

6. Preliminary Instructions

a. The instructions outlined in paragraphs 6 and 7 are preparatory to the calibration process. Personnel should become familiar with the entire bulletin before beginning the calibration.

b. Items of equipment used in this procedure are referenced within the text by common name as listed in table 2.

c. Unless otherwise specified, verify the results of each test and, whenever the test requirement is not met, take corrective action before continuing with the calibration. Adjustments required to calibrate the TI are included in this procedure. Additional maintenance information is contained in the manufacturer's manual for this TI.

d. Unless otherwise specified, all controls and control settings refer to the TI.

7. Equipment Setup

CAUTION

Do not twist the body of thermistor mount when connecting and disconnecting. Twisting can cause major damage to the thermistor mount circuit.

a. Set up multimeter to measure resistance.

b. Disconnect thermistor mount from power meter interconnect cable.

c. Connect multimeter between power meter V_{RF} center conductor (rear panel) and pin 1 of thermistor mount end of power meter interconnect cable (fig. 1).

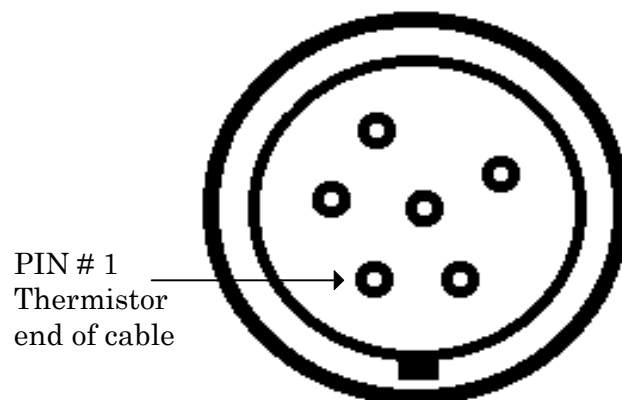

Figure 1. Thermistor cable pinout.

- d. Round off multimeter indication to two decimal places and record value as R. Reading should be $\approx 200 \Omega$.
- e. Connect thermistor mount to power meter interconnect cable.
- f. Disconnect multimeter leads from power meter.
- g. Press power meter **POWER** switch to on position.
- h. Press TI **POWER** switch to on position and allow equipment to warm-up for 30 minutes.
- i. Set power meter **CAL FACTOR** % control to value listed on TI body for 50 MHz and zero power meter.
- j. Set power meter **RANGE** switch to **1 mW**.

8. Calibrator Output

a. Performance Check

- (1) Connect frequency counter to TI **CALIBRATOR OUTPUT** connector.
- (2) Perform (a) through (d) below:
 - (a) Press **MENU** key.
 - (b) Scroll to **REF POWER ON/OFF**.
 - (c) Press **ENTER** key.
 - (d) Select **ON** and then press **ENTER** key.
- (3) Frequency counter will indicate a frequency between 49 and 51 MHz.
- (4) Set TI **POWER** switch to off position.
- (5) Connect power meter thermistor mount to TI **CALIBRATOR**.
- (6) Set power meter **RANGE** switch to **COURSE ZERO** and adjust front panel **COURSE ZERO** control for a zero indication.
- (7) Fine zero power meter on most sensitive range and then set power meter **RANGE** switch to **1 mW**.

NOTE

Ensure multimeter input leads are isolated from chassis ground.

NOTE

Set multimeter to a range that results in a resolution of $1 \mu\text{V}$.

- (8) Connect multimeter (dc mode) positive lead to power meter V_{COMP} terminal.
- (9) Connect multimeter (dc mode) negative lead to power meter V_{RF} terminal.
- (10) If multimeter indication is $400 \mu\text{V}$ or less, record multimeter indication and proceed to (12) below; if not, proceed to (11) below.

TB 9-6625-2308-35

(11) Hold power meter **FINE ZERO CONTROL** and adjust **COURSE ZERO** control for a multimeter indication of 200 μ V or less. Record multimeter indication.

(12) Round off indications recorded in (10) or (11) above to the nearest microvolt and record this value as V_0 .

(13) Set TI **POWER** switch to **ON** position.

NOTE

Multimeter indication must be taken within 15 seconds after **ENTER** key is pressed in (14) (d) below. If not, set **REF POWER** to **OFF** and repeat (14) (a) through (e) below.

(14) Perform (a) through (e) below:

- (a) Press **MENU** key.
- (b) Scroll to **REF POWER ON/OFF**.
- (c) Press **ENTER** key.
- (d) Select **ON** and then press **ENTER** key.
- (e) Record multimeter indication as V_1 .

(15) Disconnect multimeter negative lead from V_{RF} .

(16) Connect multimeter negative lead to power meter chassis ground.

(17) Record multimeter indication as V_{COMP} .

(18) Perform (a) through (d) below:

- (a) Press **MENU** key.
- (b) Scroll to **REF POWER ON/OFF**.
- (c) Press **ENTER** key.
- (d) Select **OFF** and then press **ENTER** key.

(19) Calculate the calibrator output power level using the below listed formula. If calculated results are not between 0.981 and 1.019 mW, perform **b** below.

$$P_{CAL} = \frac{2V_{COMP}(V_1 - V_0) + V_0^2 - V_1^2}{4R \text{ (CALIBRATION FACTOR)}}$$

Where:

- P_{CAL} = calibrator output power level
- V_{COMP} = value recorded in (17) above
- V_1 = value recorded in (14) (e) above
- V_0 = value recorded in (12) above
- R = value recorded in **7 d** above ($\approx 200 \Omega$)
- CALIBRATION FACTOR = thermistor mount CALIBRATION FACTOR at 50 MHz

b. Adjustments

(1) To change the setting of the power output of the calibrator, you need to know the password, if it has been set. If you do not know the password, locate jumper A2W1 located on TI analog PC board and move A2W1 to position A.

(2) Determine the percentage amount calibrator output is out of tolerance and record percentage.

Example: If calibrator output is 0.5 percent low then increase CALFAC by 0.5 percent.

(3) Press **MENU** key.

(4) Scroll to **CALIBRATOR** and press **ENTER** key.

(5) Select **EEPROM** and press **ENTER** key.

(6) Press **ENTER** key to get past **SNUMB** (unit serial number).

(7) Enter **CALFAC** change determined in (2) above.

(8) Press **ENTER** key.

(9) Correct **DATE** and press **ENTER** key.

(10) Correct **TIME** and press **ENTER** key.

(11) Select **WRITE** and then press **ENTER** key.

(12) Enter correct password if needed. (Password may be cleared or set.)

(13) Press **ENTER** key.

(14) If jumper A2W1 on analog PC board had to be moved to position A (step (1) above), return jumper A2W1 to position B.

9. Final Procedure

a. Deenergize and disconnect all equipment and reinstall protective covers on TI if necessary.

b. Annotate and affix DA label/form in accordance with TB 750-25.

SECTION IV CALIBRATION PROCESS FOR POWER SENSOR, GIGA-TRONICS MODEL 80301A

10. Preliminary Instructions

a. The instructions outlined in paragraphs **10** and **11** are preparatory to the calibration process. Personnel should become familiar with the entire bulletin before beginning the calibration.

b. Items of equipment used in this procedure are referenced within the text by common name as listed in table 2.

c. Unless otherwise specified, verify the results of each test and, whenever the test requirement is not met, take corrective action before continuing with the calibration.

TB 9-6625-2308-35

Adjustments required to calibrate the TI are included in this procedure. Additional maintenance information is contained in the manufacturer's manual for this TI.

- d. Unless otherwise specified, all controls and control settings refer to the TI.

11. Equipment Setup

CAUTION

Do not twist the body of power sensor when connecting and disconnecting. Twisting can cause major damage to the power sensor circuit.

- a. Connect equipment as shown in figure 2.

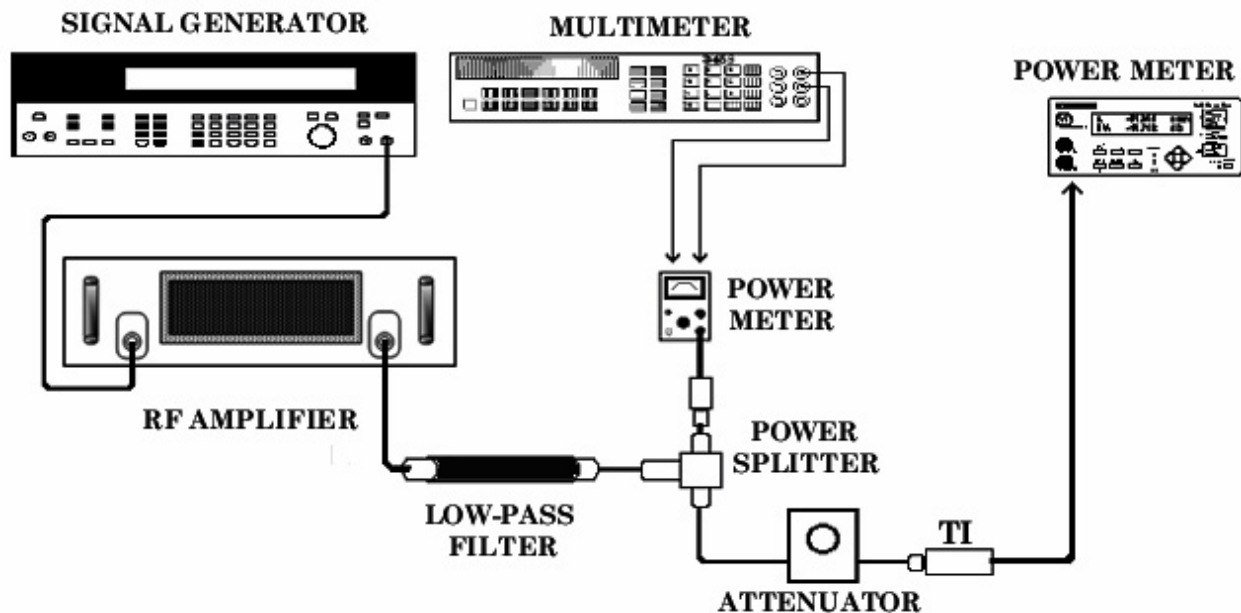

Figure 2. Power Sensor Linearity and CALFAC Equipment Hookup.

- b. Allow 30 minute equipment warm-up.

12. Power Sensor Linearity

a. Performance Check

- (1) Set the step attenuator to 70 dB. Connect TI sensor to power meter front panel **CALIBRATOR** output and zero the TI by pressing **ZERO/CAL** pushbutton.
- (2) Set the step attenuator to 0 dB after the TI chimes to signal completing the zeroing process. Reconnect sensor to equipment hook up.

- (3) Set the multimeter to a range that results in a 1 μ V resolution. Connect the positive and negative leads to the **V_{COMP}** and **V_{RF}** connectors respectively on the rear panel of the power meter.
- (4) Fine zero the power meter and set power meter **RANGE** switch to **1 mW**.
- (5) Record the multimeter indication as **V₀**.
- (6) Set the signal generator output to 50 MHz and level to 1.00 mW as indicated on the power meter.
- (7) Record multimeter reading as **V₁**. Record TI reading as **R₁** on table 3.

Table 3. Linearity Data - (+16 dBm to +20 dBm)

Step attenuator value	Power set point (mW)	Power meter reading (P)	Test instrument reading (R)	Reference power ratio	Test instrument reading ratio	Linearity error (%)	
						Linearity specification	Accumulated linearity error
0 dB	1.00 ±0.025	P ₁ =	R ₁ =	P ₁ /P ₂ =	R ₁ /R ₂ =		
	3.98 ±0.10	P ₂ =	R ₂ =			±1%	Same as Lin error above
0 dB	3.98 ±0.10	P ₁ =	R ₁ =	P ₁ /P ₂ =	R ₁ /R ₂ =		
	5.01 ±0.13	P ₂ =	R ₂ =			+1%	-1.6%
0 dB	5.01 ±0.13	P ₁ =	R ₁ =	P ₁ /P ₂ =	R ₁ /R ₂ =		
	6.31 ±0.16	P ₂ =	R ₂ =			+1%	-2.7%
0 dB	6.31 ±0.16	P ₁ =	R ₁ =	P ₁ /P ₂ =	R ₁ /R ₂ =		
	7.94 ±0.2	P ₂ =	R ₂ =			+1%	-3.8
0 dB	7.94 ±0.2	P ₁ =	R ₁ =	P ₁ /P ₂ =	R ₁ /R ₂ =		
	10 ±0.25	P ₂ =	R ₂ =			+1%	-4.9
10 dB	1.00 ±0.025	P ₁ =	R ₁ =	P ₁ /P ₂ =	R ₁ /R ₂ =		
	10.00 ±0.25	P ₂ =	R ₂ =			±1%	
20 dB	1.00 ±0.025	P ₁ =	R ₁ =	P ₁ /P ₂ =	R ₁ /R ₂ =		
	10.00 ±0.25	P ₂ =	R ₂ =			±1%	
30 dB ¹	1.00 ±0.025	P ₁ =	R ₁ =	P ₁ /P ₂ =	R ₁ /R ₂ =		
	10.00 ±0.25	P ₂ =	R ₂ =			±1%	

TB 9-6625-2308-35

Table 3. Linearity Data - (+16 dBm to +20 dBm) - Continued

40 dB	1.00 ±0.025	P ₁ =	R ₁ =	P ₁ /P ₂ =	R ₁ /R ₂ =		
	10.00 ±0.25	P ₂ =	R ₂ =			±1%	
50 dB	1.00 ±0.025	P ₁ =	R ₁ =	P ₁ /P ₂ =	R ₁ /R ₂ =		
	10.00 ±0.25	P ₂ =	R ₂ =			±1%	
60 dB ²	1.00 ±0.025	P ₁ =	R ₁ =	P ₁ /P ₂ =	R ₁ /R ₂ =		
	10.00 ±0.25	P ₂ =	R ₂ =			±1.5%	

¹Before continuing on to next attenuator setting, re-zero TI sensor by pressing [CAL], [ZERO SENSOR], [the appropriate sensor] keys. When the TI chimes, press [MEAS], [DISP], [UNITS] keys and ensure display units are set to LINEAR.

²Increase TI AVG to 8. If TI reading still is unstable, increase AVG to 16 or 32.

(8) Disconnect the multimeter negative lead from the V_{RF} connector on the rear panel of the power meter and connect it to chassis ground. Record this voltage as V_{COMP}.

(9) Calculate that actual power using the formula listed below and record as P₁ on table 3.

$$P_{CAL} = \frac{2V_{COMP}(V_1 - V_0) + V_0^2 - V_1^2}{4R(\text{CALIBRATION FACTOR})}$$

Where:

- P_{CAL} = calibrator output power level
- V_{COMP} = value recorded in (9) above
- V₁ = value recorded in (8) above
- V₀ = value recorded in (6) above
- R = value recorded in 7 d above (≈ 200 Ω)
- CALIBRATION FACTOR = value of thermistor mount at 50 MHz

(10) Connect the positive and negative leads to the V_{COMP} and V_{RF} connectors respectively on the rear panel of the power meter.

(11) Fine zero the power meter and set power meter RANGE switch to 10 mW.

(12) Record the multimeter indication as V₀.

(13) Set the signal generator output to 50 MHz and level to 3.98 mW as indicated on the power meter.

(14) Record multimeter reading as V₁. Record TI reading as R₂ on table 3.

(15) Disconnect the multimeter negative lead from the V_{RF} connector on the rear panel of the power meter and connect it to chassis ground. Record this voltage as V_{COMP}.

(16) Calculate that actual power using the formula listed below and record as P₂ on table 3.

(17) Repeat the technique of (4) through (16) above for the remaining entries on table 3.

(18) Calculate the linearity error (%) and accumulated linearity error using the formulas listed below and record in the appropriate blocks in table 3.

$$\text{Linearity Error (\%)} = \left[\left(\frac{R_1/R_2}{(P_1/P_2)} \right) - 1 \right] \times 100$$

Accumulated linearity error (%) = the sum of the current linearity error and the previous accumulated linearity error.

(19) The linearity error (%) and accumulated linearity error (%) will be within the limits specified in table 3.

b. Adjustments. No adjustments can be made.

13. Power Sensor CALFAC

a. Performance Check

- (1) Connect equipment as shown in figure 2, except remove low pass filter.
- (2) Set the step attenuator to 70 dB. Connect TI sensor to TI front panel **CALIBRATOR** output and zero the TI by pressing **ZERO/CAL**.
- (3) Set the step attenuator to 0 dB after the TI chimes to signal completing the zeroing process. Reconnect sensor to equipment hook up.
- (4) Set the multimeter to a range that results in a 1 μV resolution. Connect the positive and negative leads to the **V_{COMP}** and **V_{RF}** connectors respectively on the rear panel of the power meter.
- (5) Fine zero the power meter and set power meter **RANGE** switch to **1 mW**.
- (6) Record the multimeter indication as **V₀**.
- (7) Set the signal generator output to 1.0 GHz and level to 1.00 mW as indicated on the power meter.
- (8) Record multimeter reading as **V₁**. Record TI reading as **P_i**.
- (9) Disconnect the multimeter negative lead from the **V_{RF}** connector on the rear panel of the power meter and connect it to chassis ground. Record this voltage as **V_{COMP}**.
- (10) Calculate that actual power using the formula listed below and record as **P_t**.

$$P_t = \frac{2V_{COMP}(V_1 - V_0) + V_0^2 - V_1^2}{4R \text{ (CALIBRATION FACTOR)}}$$

Where:

- P_t** = Actual incident power
- V_{COMP}** = value recorded in (9) above
- V₁** = value recorded in (8) above
- V₀** = value recorded in (6) above
- R** = value recorded in **7 d** above (≈ 200 Ω)
- CALIBRATION FACTOR** = value of thermistor mount at 50 MHz

TB 9-6625-2308-35

(11) Using the formula below, calculate KB.

$$KB = \left[\frac{P_t}{P_i} \right] \times 100$$

(12) If TI displayed power is not within $\pm 1.61\%$ of calculated P_t , perform **b** below.

(13) Repeat technique of (2) through (11) above for frequencies and tolerances listed in table 4. Make appropriate changes to sensor CALFAC as required using technique in **b** below.

Table 4. Sensor CALFAC

Frequency (GHz)	Tolerance
2.0	$\pm 1.95\%$
3.0	$\pm 2.44\%$
4.0	$\pm 2.44\%$
5.0	$\pm 2.67\%$
6.0	$\pm 2.67\%$
7.0	$\pm 2.86\%$
8.0	$\pm 2.86\%$
9.0	$\pm 3.59\%$
10.0	$\pm 3.59\%$
11.0	$\pm 3.59\%$
12.0	$\pm 3.59\%$
13.0	$\pm 4.09\%$
14.0	$\pm 4.09\%$
15.0	$\pm 4.09\%$
16.0	$\pm 4.09\%$
17.0	$\pm 4.09\%$
18.0	$\pm 4.09\%$

b. Adjustments

- (1) Press TI **MENU**, **SERVICE**, **SENSOR ROM** softkeys.
- (2) Scroll cursor to appropriate CALFAC and change to KB calculated in (11) above.
- (3) Press **ENTER**.

14. Final Procedure

- a.** Deenergize and disconnect all equipment and reinstall protective covers on TI if necessary.
- b.** Annotate and affix DA label/form in accordance with TB 750-25.

By Order of the Secretary of the Army:

Official:



JOEL B. HUDSON

*Administrative Assistant to the
Secretary of the Army*

0424511

PETER J. SCHOOMAKER

*General, United States Army
Chief of Staff*

Distribution:

To be distributed in accordance with the initial distribution number (IDN) 344603, requirements TB 9-6625-2308-35.

INSTRUCTIONS FOR SUBMITTING AN ELECTRONIC 2028

The following format must be used if submitting an electronic 2028. The subject line must be exactly the same and all fields must be included; however, only the following fields are mandatory: 1, 3, 4, 5, 6, 7, 8, 9, 10, 13, 15, 16, 17, and 27.

From: "Whomever" whomever@redstone.army.mil

To: <2028@redstone.army.mil

Subject: DA Form 2028

1. **From:** Joe Smith
2. **Unit:** home
3. **Address:** 4300 Park
4. **City:** Hometown
5. **St:** MO
6. **Zip:** 77777
7. **Date Sent:** 19-OCT-93
8. **Pub no:** 55-2840-229-23
9. **Pub Title:** TM
10. **Publication Date:** 04-JUL-85
11. **Change Number:** 7
12. **Submitter Rank:** MSG
13. **Submitter FName:** Joe
14. **Submitter MName:** T
15. **Submitter LName:** Smith
16. **Submitter Phone:** 123-123-1234
17. **Problem:** 1
18. **Page:** 2
19. **Paragraph:** 3
20. **Line:** 4
21. **NSN:** 5
22. **Reference:** 6
23. **Figure:** 7
24. **Table:** 8
25. **Item:** 9
26. **Total:** 123
27. **Text**

This is the text for the problem below line 27.

